

Fahrzeug-Zustandsbericht

Vehicle Condition Report

ID Nummer/ ID Number	Ankunftsort/ Place of Arrival
Model/ Type	Kennzeichen/ Licence Number
Chassis Nummer/ Chassis Number	Abfahrtsdatum/ Date of Departure
Abfahrtsort/ Place of Departure	Ankunftsdatum/ Date of Arrival

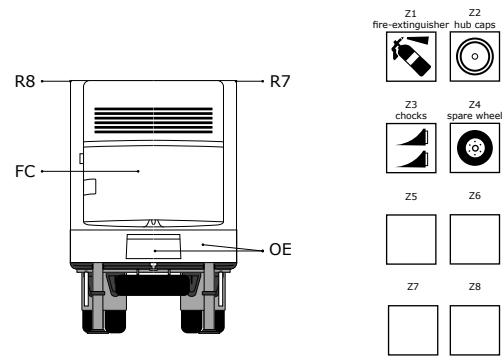
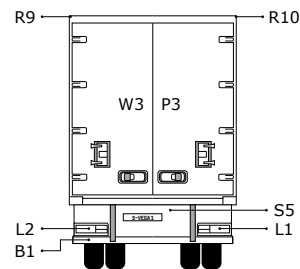
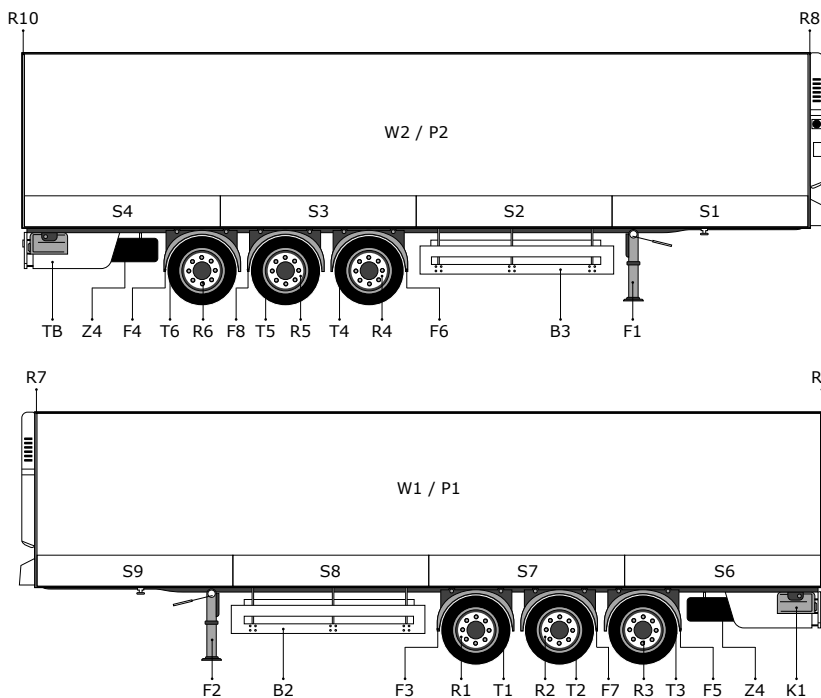

Damage codes	Beschädigungscodes	Dommage code	Codici danni	Hasar kodlari	код повреждения
0= OK	0= OK	0= OK	0= OK	0= OK	0= ок
1= missing	1= fehlt	1= manquer	1= manca	1= eksik	1= отсутствует
2= scratch	2= Kratzer	2= griffure	2= graffio	2= cizik	2= царапина
3= broken	3= gebrochen	3= cassée	3= rotto	3= kirik	3= сломанный
4= dent	4= Delle	4= concave	4= concavo	4= centik	4= вмятина
5= cut	5= Schnitt	5= décaupage	5= taglio	5= kesik	5= порез
6= cracked	6= Sprung	6= crevasse	6= crepato	6= catlak	6= трещина
7= damaged	7= beschädigt	7= dommage	7= danno	7= hasar	7= повреждение
8= factory fault	8= Fabrikationsfehler	8= défaut de fabrication	8= difetto di fabbrica	8= Fabrika hatasi	8= производственный брак

Zustand bei/ condition at	festgestellt von/ noted by	Codes, Stelle, Schaden, Ausmaß/ codes, position, damage, size	Unterschrift, Stempel/ signature, stamp	Name / name
1 Beladung/ loading	Transport Firma/ transport company			
2 Abgangshafen/ port departure	Agent-Abgangshafen/ agent			
3 Schiffsabfahrt/vessel departure	Verschiffungslinie/ shipping line			
4 Schiffsankunft/ vessel arrival	Verschiffungslinie/ shipping line			
5 Ankunftshafen/ port arrival	Agent-Abgangshafen/ agent			
6 Zustellung/ delivery	Empfänger/ receiver			
Bemerkungen/remarks				

Fahrzeug-Zustandsbericht

Vehicle Condition Report

ID Nummer/ ID Number	Ankunftsort/ Place of Arrival
Model/ Type	Kennzeichen/ Licence Number
Chassis Nummer/ Chassis Number	Abfahrtsdatum/ Date of Departure
Abfahrtsort/ Place of Departure	Ankunftsdatum/ Date of Arrival

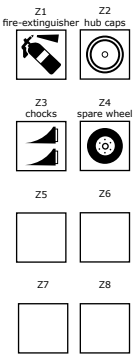
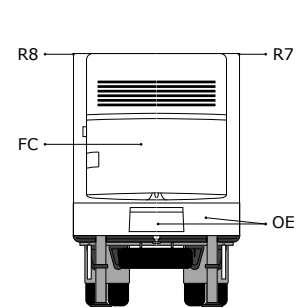
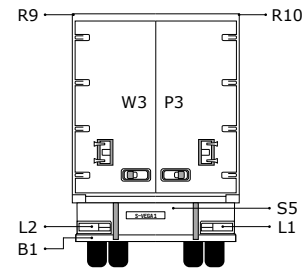
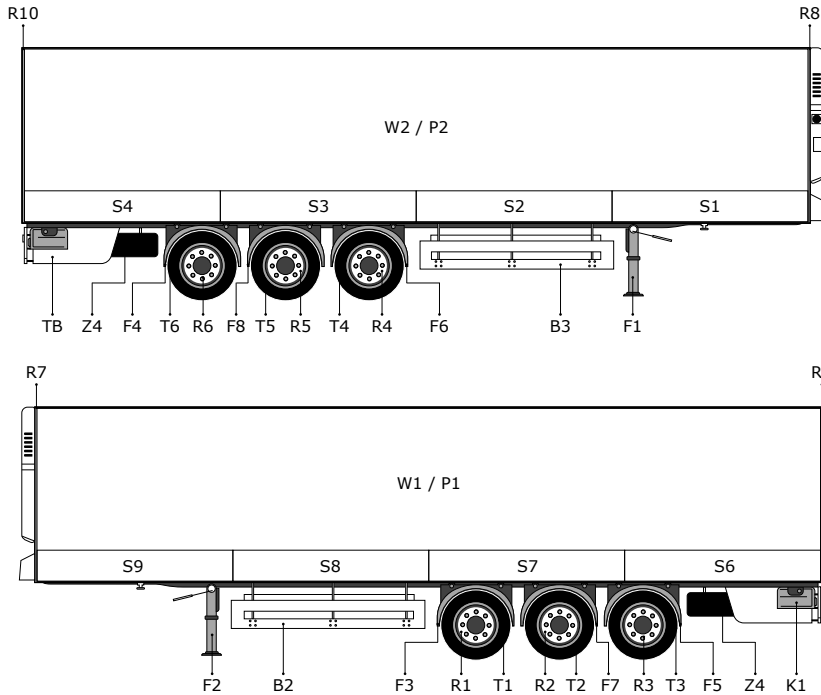

Damage codes	Beschädigungscodes	Dommage code	Codici danni	Hasar kodlari	код повреждения
0= OK	0= OK	0= OK	0= OK	0= OK	0= ок
1= missing	1= fehlt	1= manquer	1= manca	1= eksik	1= отсутствует
2= scratch	2= Kratzer	2= griffure	2= graffio	2= cizik	2= царапина
3= broken	3= gebrochen	3= cassée	3= rotto	3= kirik	3= сломанный
4= dent	4= Delle	4= concave	4= concavo	4= centik	4= вмятина
5= cut	5= Schnitt	5= décaupage	5= tagilo	5= kesik	5= порез
6= cracked	6= Sprung	6= crevasse	6= crepato	6= catlak	6= трещина
7= damaged	7= beschädigt	7= dommage	7= danno	7= hasar	7= повреждение
8= factory fault	8= Fabrikationsfehler	8= défaut de fabrication	8= difetto di fabbrica	8= Fabrika hatasi	8= производственный брак

Zustand bei/ condition at	festgestellt von/ noted by	Codes, Stelle, Schaden, Ausmaß/ codes, position, damage, size	Unterschrift, Stempel/ signature, stamp	Name / name
1 Beladung/ loading	Transport Firma/ transport company			
2 Abgangshafen/ port departure	Agent-Abgangshafen/ agent			
3 Schiffsabfahrt/vessel departure	Verschiffungslinie/ shipping line			
4 Schiffsankunft/ vessel arrival	Verschiffungslinie/ shipping line			
5 Ankunftshafen/ port arrival	Agent-Abgangshafen/ agent			
6 Zustellung/ delivery	Empfänger/ receiver			
Bemerkungen/remarks				